

ELV, RoHS COMPLIANT

NOTES

1. RECOMMENDED REFLOW PROFILE (SEE RIGHT GRAPF)
TYPE: IR REFLOW
ATMOSPHERE: AIR OR N2
CYCLE TIME: UP TO 2 CYCLES OF REFLOW SOLDERING ARE POSSIBLE UNDER THE CONDITIONS, PROVIDED THAT THERE IS A RETURN TO NOMAL TEMPERATURE BETWEEN THE FIRST AND SECOND CYCLE.
PEAK TEMPERATURE: 250°C
230°C MIN. FOR 20 TO 40 SECONDS.
PREHEATING AREA 150~180°C FOR 60 TO 120 SECONDS.
2. HAND SOLDERING: 280-300°C, 2S MAX.
3. CONTACT COPLANARITY: 0.1mm MAX.
4. RECOMMENDED THICKNESS OF PCB: 1.6mm
5. RECOMMENDED THICKNESS OF SOLDERING PASTE: 0.15mm

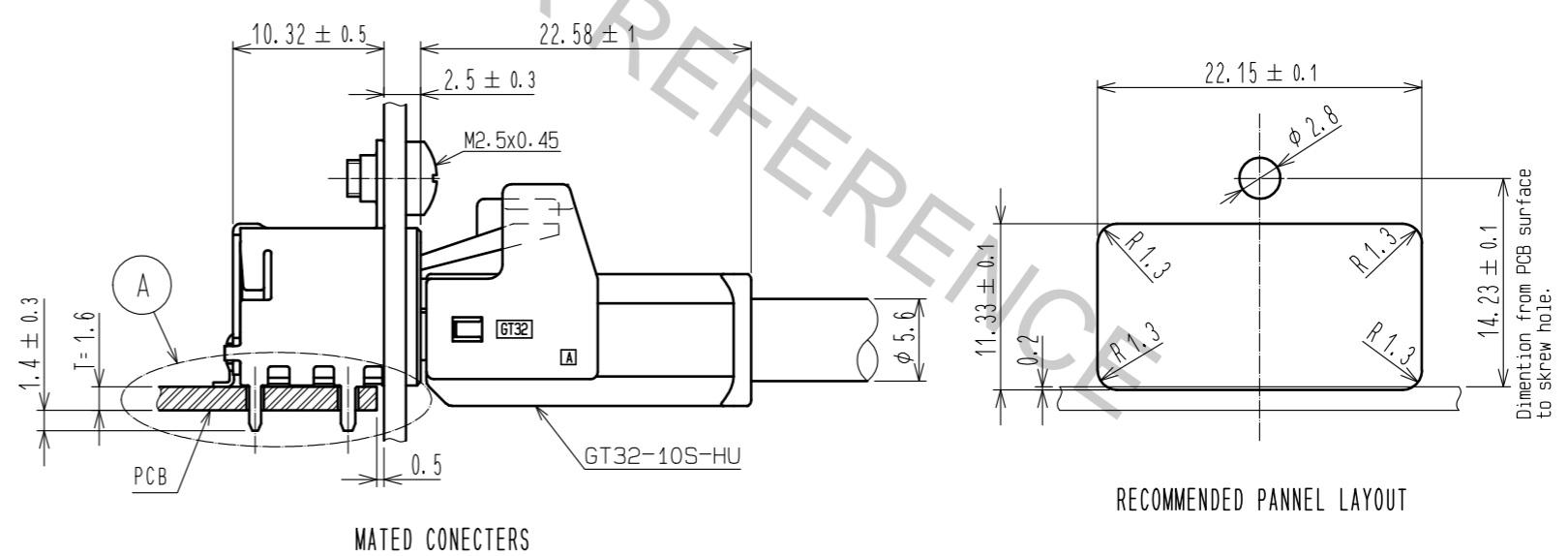
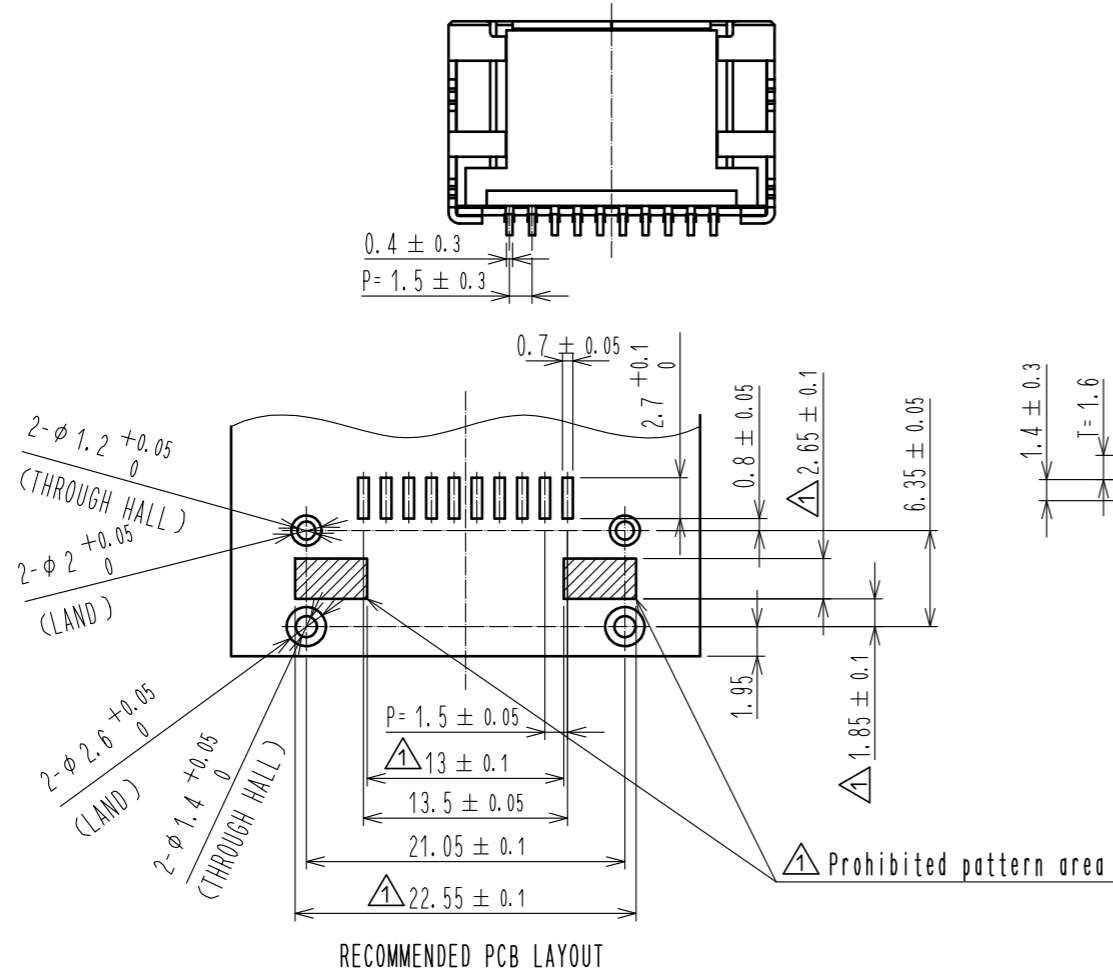
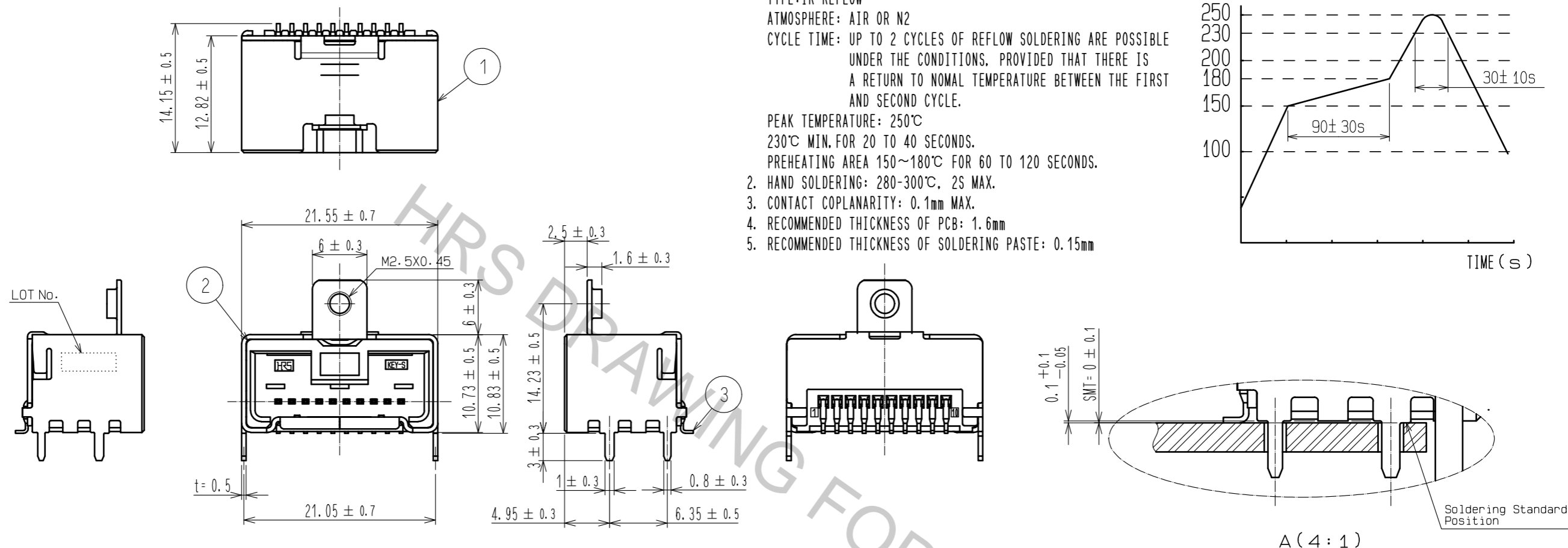
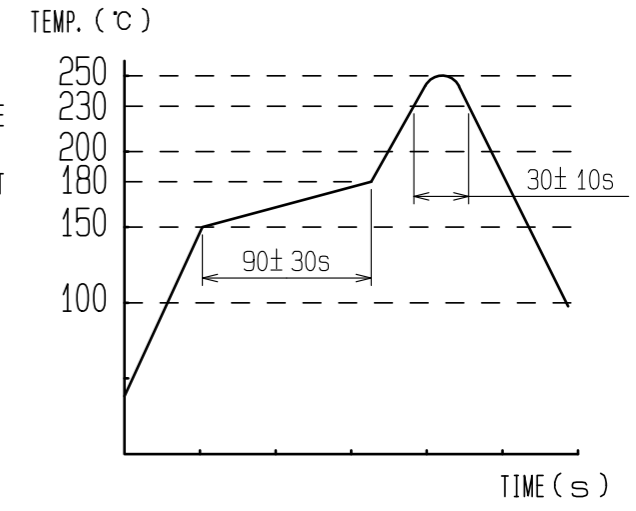

2	PPS	LIGHT GRAY			
1	COPPER ALLOY	TIN PLATED	3	BRASS	TIN PLATED
NO.	MATERIAL	FINISH . REMARKS	NO.	MATERIAL	FINISH . REMARKS
UNITS	mm	SCALE	COUNT	DESCRIPTION OF REVISIONS	
		2 : 1	1	DIS-T-00001389	
APPROVED : AR. SHIRAI		11.03.25		DESIGNED	
CHECKED : NH. NAKATA		11.03.24		CHECKED	
DESIGNED : TS. KUBOTA		11.03.18		DATE	
DRAWN : TS. KUBOTA		11.03.18		16.08.24	
DRAWING NO.			EDC3-168176-00		
PART NO.			GT32-10P-1.5H		
CODE NO.			CL782-0001-1-00		

Apr.1.2017 Copyright 2017 HIROSE ELECTRIC CO., LTD. All Rights Reserved.

△ PACKAGE SPECIFICATIONS

- ①. Place the connectors into the tray. (Cf. Figure of tray shape)
QTY per tray: 77pcs
- ②. Put the tray for six steps in turn and wind up a PP band.
Top(the sixth step) is an empty tray.
- ③. Put it in a cardboard box (W=270 H=150 D=360)
QTY per cardboard: 385 pcs

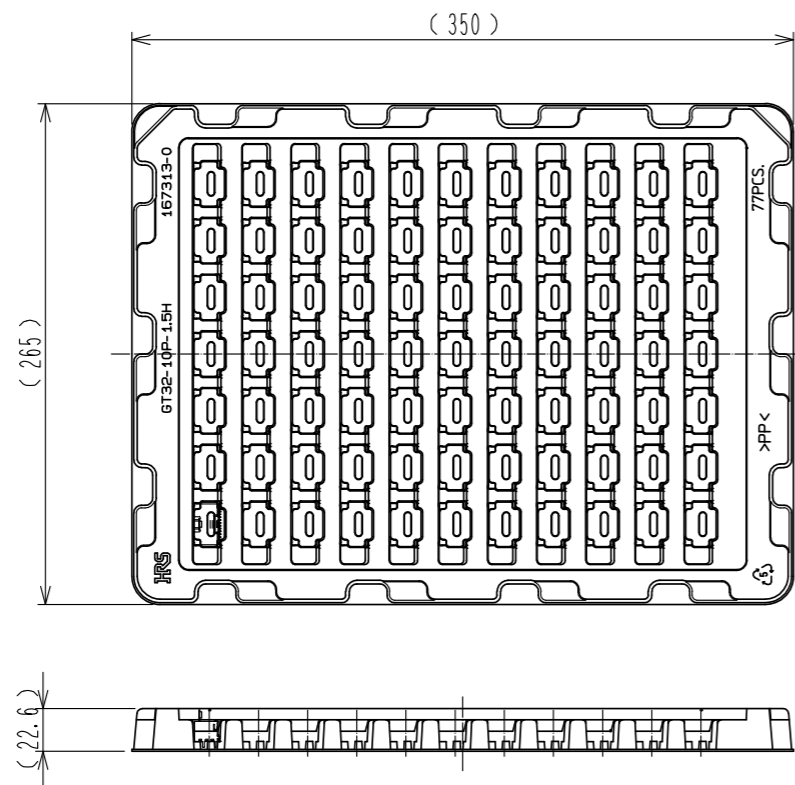

Figure of tray shape (1:4)

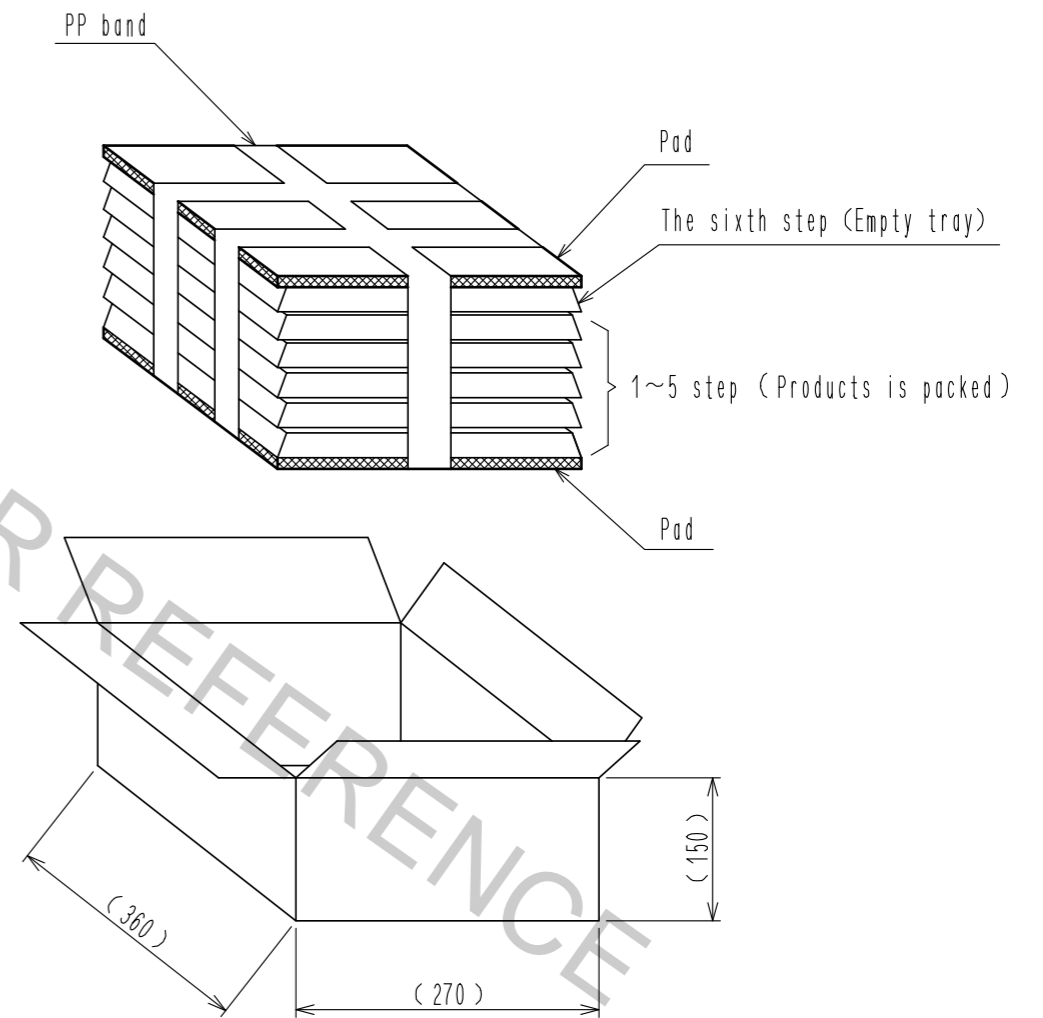

Figure of packing

HRS

図番: EDC3-168176-00
 製品名: GT32-10P-1.5H
 製品コード: CL782-0001-1-00

△ 2/2