

Apr.1.2017 Copyright 2017 HIROSE ELECTRIC CO., LTD. All Rights Reserved.

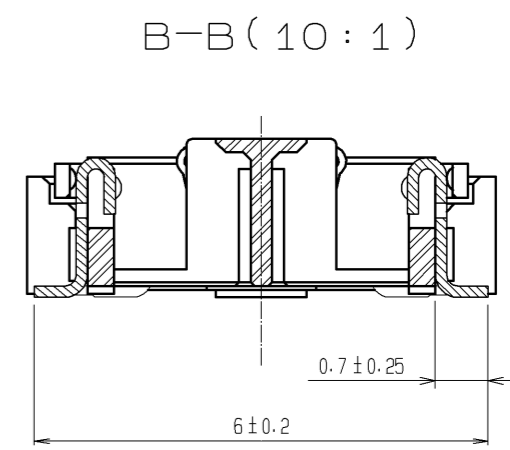

RECOMMENDED LAND PATTERN DIMENSION OF PCB  
(RECOMMENDED METAL MASK THICKNESS: 0.15mm)

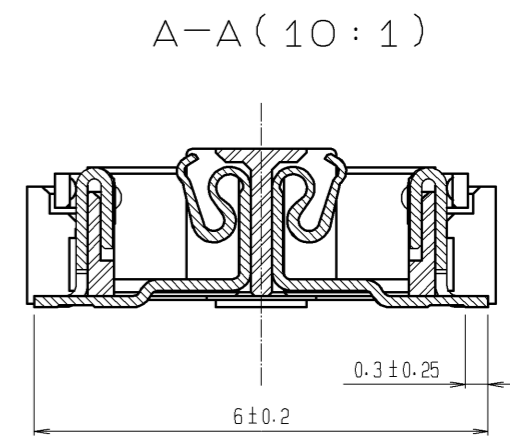
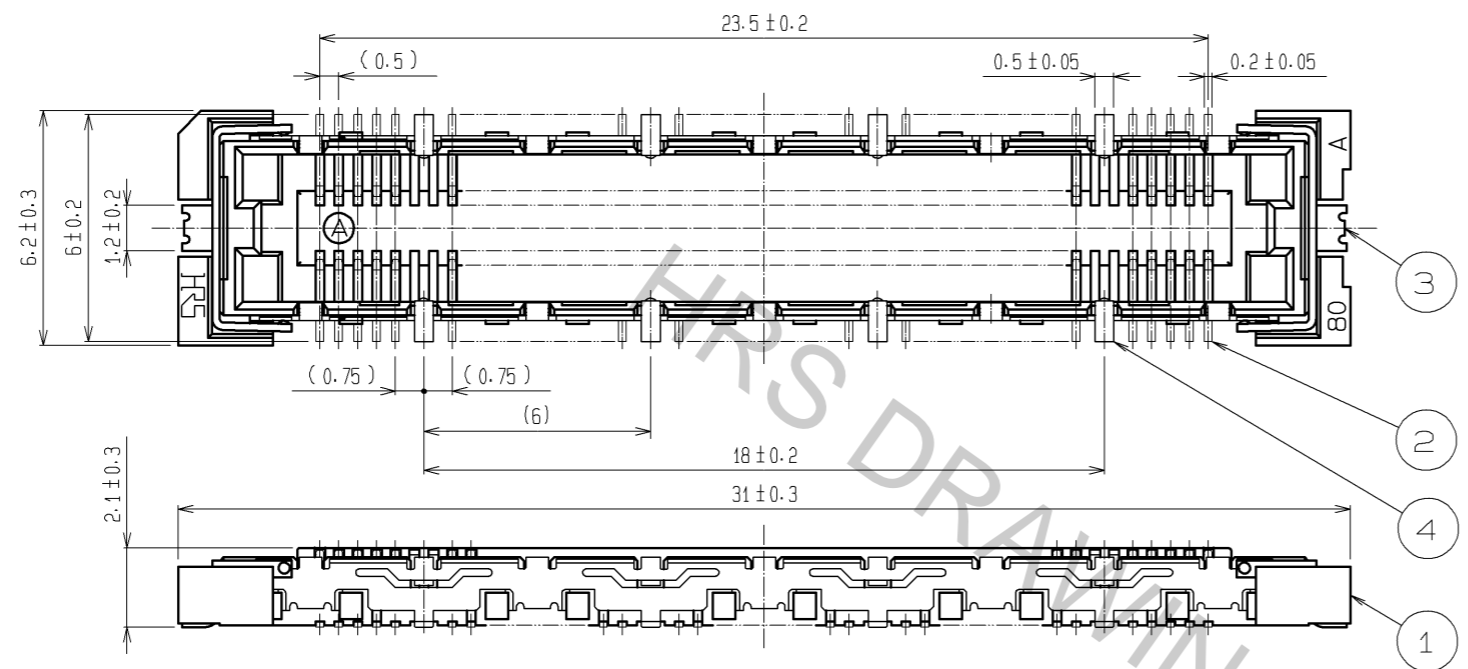
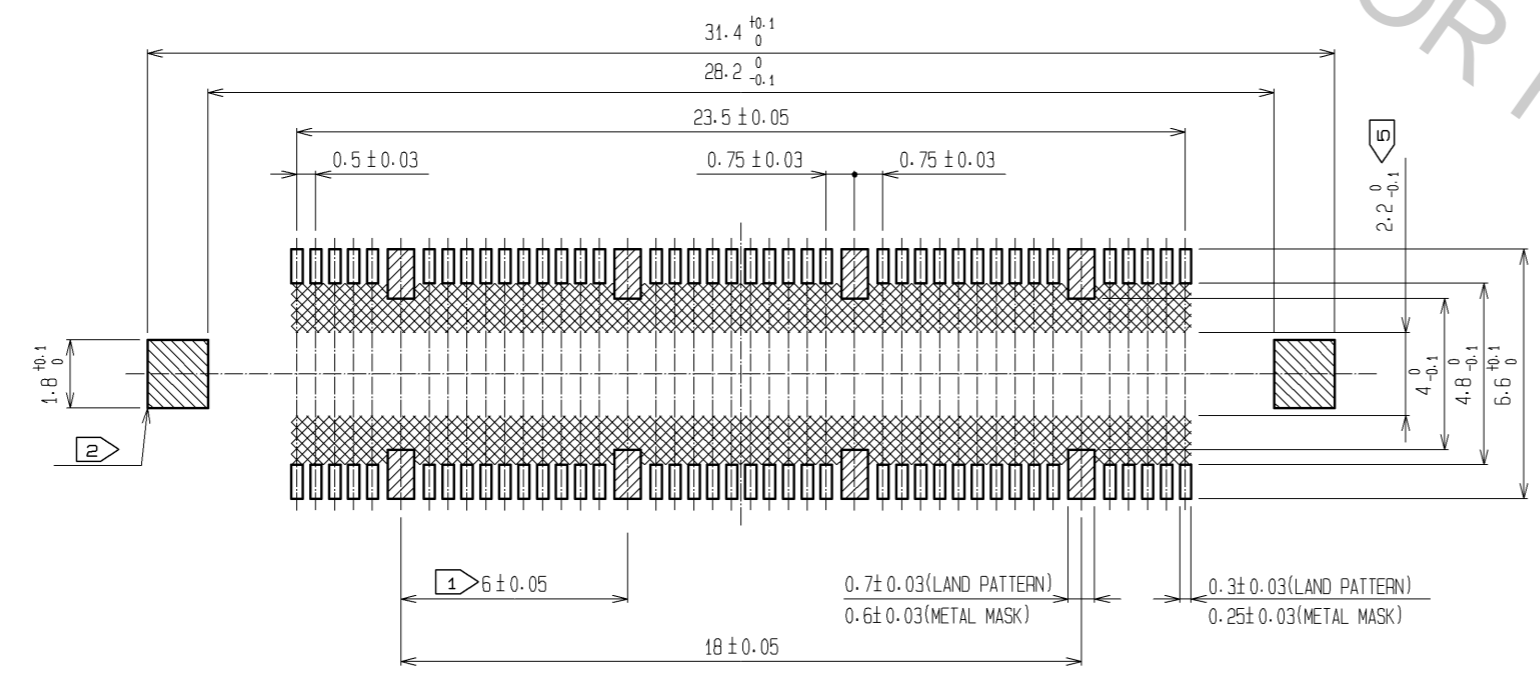

- NOTES
- ① 8 HATCHED PARTS: GROUND CIRCUIT.
  - ② 2 HATCHED PARTS: GROUND CIRCUIT.
  - ③ SMT LEAD-COPLANARITY: 0.1 MAX.
  - ④ THIS PRODUCT HAS NO POLARITY TO PATTERN FOR MOUNTING.
  - ⑤ MAKE SURE WIDTH OF PATTERN IS WITHIN THAT OF LAND .OR LEAD MAY TOUCH PATTERN. (THIS APPLIES TO HATCHED AREA.)
  - ⑥ THE DIMENSIONS IN PARENTHESES ARE FOR REFERENCE.

1	LCP	BEIGE	UL94V-0	3, 4	PHOSPHOR BRONZE	TIN PLATING		
2				2	PHOSPHOR BRONZE	CONTACT AREA : GOLD 0.1μm min. LEAD AREA : GOLD 0.05μm min. UNDER PLATING : NICKEL 1μm min.		
NO.	MATERIAL	FINISH	REMARKS	NO.	MATERIAL	FINISH . REMARKS		
UNITS	mm	SCALE	5 : 1	COUNT	DESCRIPTION OF REVISIONS	DESIGNED	CHECKED	DATE
APPROVED : HS. OKAWA		09.10.19		DRAWING NO.		EDC3-152637-25		
CHECKED : HT. YAMAGUCHI		09.10.19		PART NO.		FX11B-80S/8-SV(71)		
DESIGNED : SY. KAMIGA		09.10.17		CODE NO.		CL573-0713-5-71		
DRAWN : HK. SUNADORI		09.10.17						