

5

4

3

2

1

DRAWING NO.

CPMC782-CUST

REVISIONS

01	OFFICAL RELEASE				
	03-05-09	Z	B	T	
02	RELEASE FOR SUPPLIER ALTER				
	07-27-11	Y	Y	M	



Description: Plug Assembly, Straight Crimp Type BNC 75 Ohm, RG59, 62

Part No: CPMC782

Application: For Cable BELDEN 1505A, RG59, 62

Crimp Tool: 24-9959P

Impedance: 75 Ohms

Fequency Range: 0-2 GHz

Material:

Body	Brass	Nickel Plated
Contact	Brass	Gold Plated
Insulator	PTFE	
Crimp Sleeve	Brass	Nickel Plated
Coupling Nut	Zinc	Nickel Plated

RoHS Compliance: Yes

Technical Detail: Refer to Emerson Document P/N 27-0000

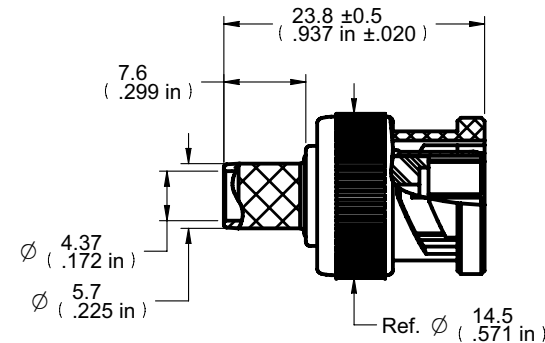
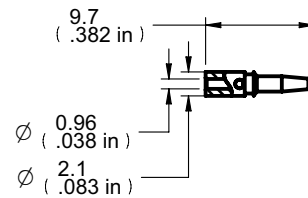
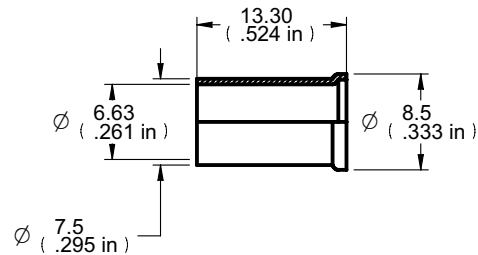

DIM OUTLINE

CUSTOMER COPY

受控 CONTROLLED DOCUMENT					
编号 P/N	CPMC782-CUST	版本 Rev	02	日期 Rel'd Date	Aug4,11

TOLERANCE UNLESS OTHERWISE SPECIFIED		DRAWN BY YUGE HU	DATE 07-27-11
DECIMALS	mm	CHECKED BY YUGE HU	DATE 07-27-11
X	± 0.5	APPROVED BY LIN MA	DATE 07-27-11
X.X	± 0.3	U/M	mm
X.XX	± 0.1		
ANGLES	± 0.5°		

THIS DRAWING WAS PRODUCED BY COMPUTER,
DO NOT SCALE DRAWING OR UPDATE MANUALLY.

SHEET
1 OF 1

DRAWING NO.
CPMC782-CUST

SIZE
A



TITLE
PLUG ASSEMBLY, STRAIGHT CRIMP
TYPE, BNC 75OHM, RG59, 62

5

4

3

2

1